

# SPECIFICATION SUBMITTAL SHEET

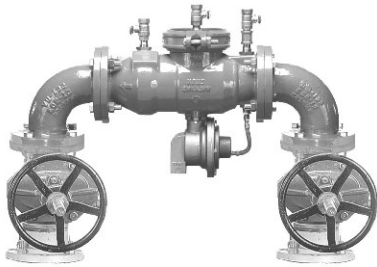

### FEATURES

Sizes:  2 1/2"  3"

Maximum working water pressure 175 PSI  
 Maximum working water temperature 140°F  
 Hydrostatic test pressure 350 PSI  
 End connections (Grooved for steel pipe) AWWA C606-87  
 (Flanged) ANSI B16.1  
 Class 125

### OPTIONS (Suffixes can be combined)

- with NRS shut-off valves (standard)
- FS - with cast iron wye type strainer (flanged only)
- FSC - with epoxy coated wye type strainer (flanged only)
- G - with groove end gate valves
- FG - with flanged inlet gate connection and grooved outlet gate connection
- L - less shut-off valves (flanged body connections)
- OSY - with OS & Y gate valves
- MS - with Integral Relief Valve Monitor Switch
- V - vertical flow up configuration

### ACCESSORIES

- Repair kit (rubber only)
- Thermal expansion tank (Model WXTP)
- Valve setter (Model FLS or MJS or MJFS)
- Gate valve tamper switch (OSY-40)
- Air gap (Use Model AG-6)
- QT-SET Quick Test Fitting Set
- Electronic Solenoid Timer (Model EST)
- Test Cock Lock (Model TCL24)

### APPLICATION

Designed for installation on potable water lines to protect against both backsiphonage and backpressure of contaminated water into the potable water supply. Assembly shall provide protection where a potential health hazard exists. The Model 475 is for applications requiring vertical flow up and vertical flow down. The Model 475V is for applications requiring vertical flow up.

### STANDARDS COMPLIANCE

- ASSE® Listed 1013
- AWWA Compliant C511
- CSA® Certified
- IAPMO® Listed
- UL® Classified
- C-UL® Classified
- FM® Approved
- Approved by the Foundation for Cross Connection Control and Hydraulic Research at the University of Southern California

### MATERIALS

Main valve body Ductile Iron ASTM A 536 Grade 4  
 Access covers Ductile Iron ASTM A 536 Grade 4  
 Coatings FDA Approved fusion epoxy finish  
 Internals Stainless steel, 300 Series  
 NORYL™, NSF Listed  
 Fasteners Stainless Steel, 300 Series  
 Elastomers EPDM (FDA approved)  
 Buna Nitrile (FDA approved)  
 Polymers NORYL™, NSF Listed  
 Springs Stainless steel, 300 series  
 Sensing line Stainless steel, braided hose

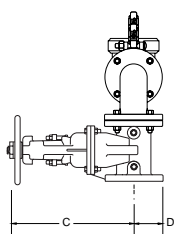

Model 475

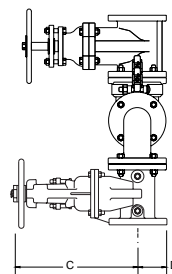
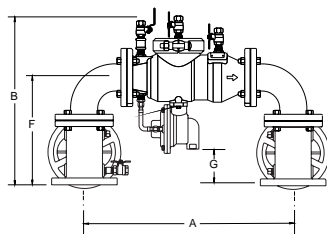

Model 475V

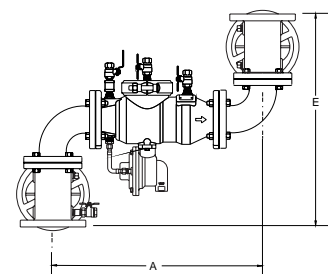

Relief Valve discharge port:  
 2 1/2" - 6" - 2.75 sq. in.

### DIMENSIONS & WEIGHTS (do not include pkg.)

MODEL SIZE	DIMENSION (approximate)																WEIGHT								
	A		B		C OS&Y OPEN		C OS&Y CLOSED		C NRS GATE		D		E		F		G		WITHOUT GATE VALVES		WITH NRS GATE VALVES		WITH OS&Y GATE VALVES		
	in.	mm	in.	mm	in.	mm	in.	mm	in.	mm	in.	mm	in.	mm	in.	mm	in.	mm	lbs.	kg	lbs.	kg	lbs.	kg	
2 1/2	65	26 1/4	667	20 1/2	521	16 3/8	416	13 7/8	352	11 3/8	289	3 3/4	95	26 1/8	664	13 1/8	333	4 1/8	105	87	39.5	196	88.9	205	93.1
3	80	27 1/4	692	21 1/2	546	18 7/8	479	15 5/8	397	12 3/8	314	3 3/4	95	27 1/8	689	13 9/16	345	4 9/16	116	112	50.8	234	106.2	240	109

## MODEL 475 & 475V 2 1/2" & 3" (STANDARD & METRIC)

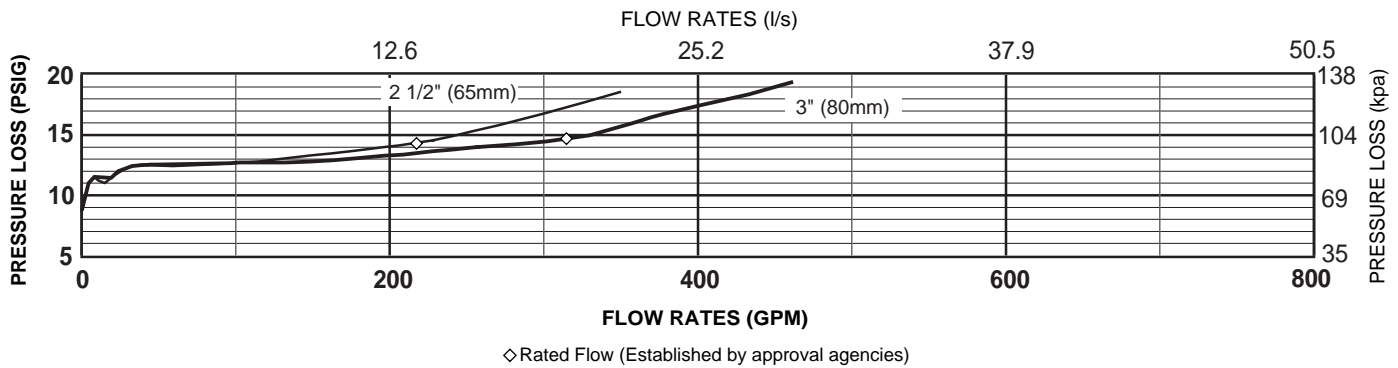

### TYPICAL INSTALLATION

Local codes shall govern installation requirements. To be installed in accordance with the manufacturers' instructions and the latest edition of the Uniform Plumbing Code. Unless otherwise specified, the assembly shall be mounted at a minimum of 12" (305mm) and a maximum of 30" (762mm) above adequate drains with sufficient side clearance for testing and maintenance. The installation shall be made so that no part of the unit can be submerged.

Capacity thru Schedule 40 Pipe (GPM)				
Pipe size	5 ft/sec	7.5 ft/sec	10 ft/sec	15 ft/sec
2 1/2"	75	112	149	224
3"	115	173	230	346
4"	198	298	397	595
6"	450	675	900	1351
8"	780	1169	1559	2339
10"	1229	1843	2458	3687

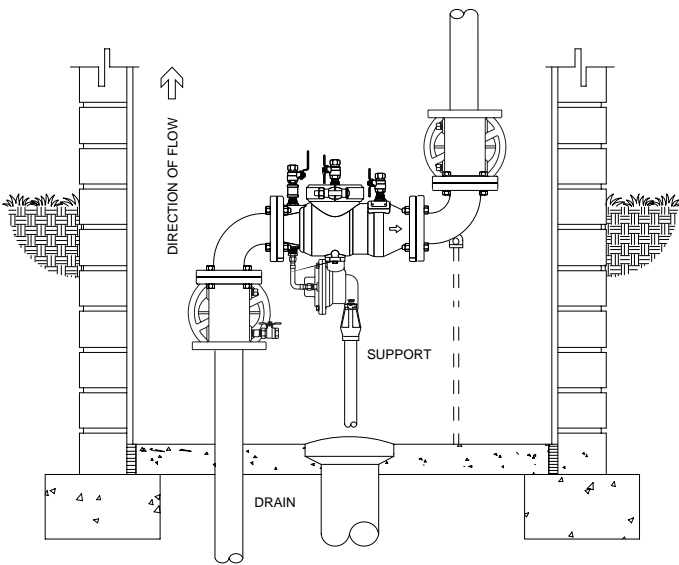

INDOOR INSTALLATION

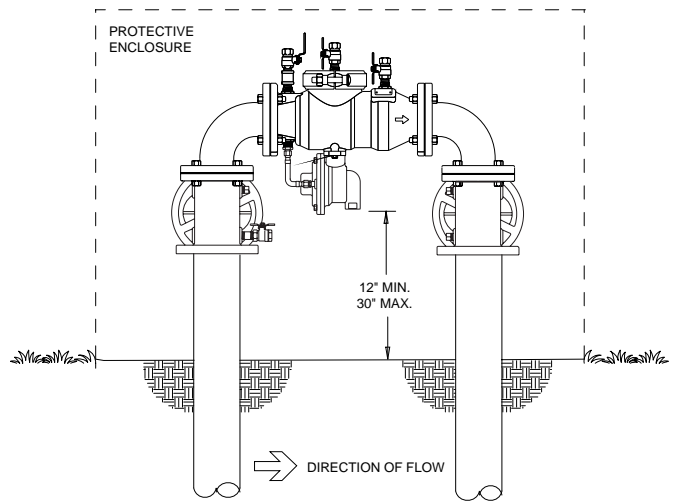

OUTDOOR INSTALLATION

### SPECIFICATIONS

The Reduced Pressure Principle Backflow Preventer shall be ASSE® Listed 1013, and supplied with full port gate valves. The main body and access covers shall be epoxy coated ductile iron (ASTM A 536 Grade 4), the seat ring and check valve shall be NORYL™, the stem shall be stainless steel (ASTM A 276) and the seat disc elastomers shall be EPDM. Center stem guided design shall incorporate two torsion springs to bias the check in the closed position. The first and second checks shall be accessible for maintenance without removing the relief valve or the entire device from the line. If installed indoors, the installation shall be supplied with an air gap adapter. The Reduced Pressure Principle Backflow Preventer shall be a WILKINS Model 475 or 475V.